



DATA SHEET FOR FLP FLOOD LIGHT FITTING

FLP-WP-FLOOD LIGHT UP TO 80 WATT LED

TECHNICAL DATA:

PRODUCT	: CAT. NO. – WG/1240
ENCLOSURE	: FLAME PROOF (Ex –d), Gas Group IIA , IIB , IIC As per IS/IEC 60079-1 : 2014
PROTECTION	: WEATHER PROOF IP – 66 AS PER IS/IEC 60529:2001 (Reaffirmed 2014)
AREA CLASSIFICATION	: Ex db IIC T6 Gb (EX tb / tc IIIC T85 C Db/Dc (ZONE 1 & 2 & Zone 21 & 22)
CERIFICATION	: CIMFR, BIS, PESO
TEMPERATURE CLASS	: T 6
MATERIAL	: DIE CAST ALUMINIUM ALLOY
FINISH	: EPOXY POWDER COATED SHADE AS PER IS : 5
EARTHING	: 1 No INTERNAL & 2 No's EXTERNAL
HARDWARE	: STAINLESS STEEL
GASKET	: 'O' RING ENDLESS GASKET NEOPRENE / SILICON
NAME PLATE	: SS NAME PLATE CUM WARNING PLATE
GLASS	: HEAT RESISTANT CLEAR TYPE-A TOUGHENED GLASS
ENTRIES	: 2 Nos M20 / ½ " NPT / EQUIVALENT
VOLTAGE	: 140 V – 270 V (240 V AC)
POWER FACTOR	: ≥ 0.95
INPUT FREQUENCY	: 50 Hz.
EFFICACY	: ≥ 100 LUMEN PER WATT
COLOUR (CCT)	: 3000K / 5700K / 6500 K / OR AS SPECIFIED
CRI	: ≥ 80 RA
THD	: ≤ 10 % THD
SURFACE TEMP.	: MAX . 70°
SURGE PROTECTION	: 10 KV SPD
LED MAKE	: CITIZEN / OSRAM / BRIDGELUX / EQUIVALENT
DRIVER MAKE	: OSRAM / PHILIPS / FULHAM / EQUIVALENT - BIS APPROVED

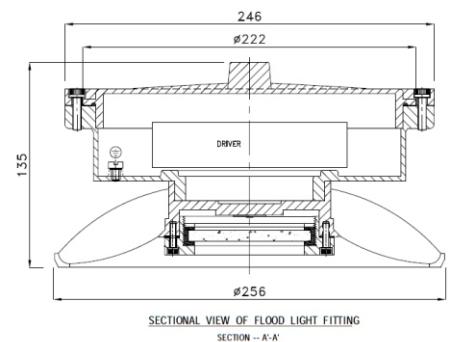
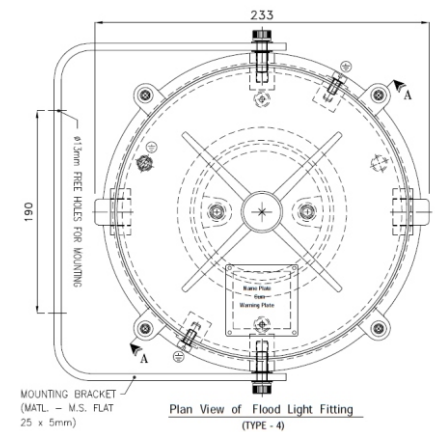

OPTIONS

SR.NO	PARTICULAR	OPTIONS
1.	MATERIAL OF CONSTRUCTION	STAINLESS STEEL
2.	VOLTAGE	220V DC / 110 V AC / 110 V DC / 24 V AC
3.	BEAM ANGLE	LENS AVAILABLE 60/90/120 DEGREE
4.	LED TYPE	COB / SMD
5.	BATTERY BACK UP	UP TO 90 MINS
6.	GLAND & PLUG	BRASS / SS / ALUMINIUM
7.	COLOUR SHADE	631 , 632 , 355 , 7031 , 7032 etc.
8.	WIRE GUARD	MS WHITE EPOXY POWDER COATED / SS

SELECTION CHART

SR.NO	WATTAGE	PART NO
1	50	WG/1240 / FL / 50
2	60	WG/1240 / FL / 60
3	70	WG/1240 / FL / 70
4	75	WG/1240 / FL / 75
5	80	WG/1240 / FL / 80

